

LF311 Datasheet

LOW-FLOW PRESSURE REGULATOR



Gas
 Liquid
 Diaphragm
 Piston
 Self-Venting
 Non-Venting
 Max Inlet: 414 bar (6,000 psi)
 Max Outlet: 180 bar (2,610 psi)
 Cv 0.06

Image for illustration purposes only



INTRODUCING THE LF311...

The LF311 is a single-stage piston-sensed pressure regulator for applications that require higher supply pressures in addition to an extended life cycle.

Based on the LF301, the LF311 also offers a 'solid disk' seat design which is more robust for aggressive or high temperature applications.

SPECIFICATION

Max. Rated Inlet Pressure	414 bar (6,000 psi)
Outlet Ranges	Up to 180 bar (2,610 psi)
Design Proof Pressure	150% max. working pressure
Seat Leakage	In accordance with ANSI/FCI 70-3
Weight	0.9kg (2lbs)

STANDARD MATERIALS OF CONSTRUCTION

PART	MATERIALS
Body and Bonnet	ASTM A479 316/316L Stainless Steel (UNS S31600/S31603)
Main Valve Pin	ASTM A479 316/316L Stainless Steel
Soft Seat	PEEK™ (450G) PCTFE (Kel-F)
Valve Spring	Inconel® X750
Piston	ASTM A479 316/316L Stainless Steel
Handwheel	Nylon
O-Rings	FKM/FPM (Viton)
Loading Spring	ASTM A240 301 Stainless Steel (UNS S30100)
Filter	40 Microns

Note: Pressure regulator rating may be limited by connection type, Cv and/or seat material. Contact the office for specific pressure or temperature requirements.

FEATURES AND BENEFITS

1 PISTON SENSING ELEMENT

Perfect for use in challenging conditions.

2 316SS THREADED BONNET

For panel mounting option as standard.

3 40 MICRON INLET FILTER

First stage soft seat protection from system contamination.

4 SOLID DISK SEAT DESIGN

Robust design enabling higher inlet pressures of up to 414 bar (6,000 psi).

Product availability and specifications contained herein are subject to change without notice. Consult local distributor or factory for potential revisions and/or service related issues. Pressure Tech Ltd support with product selection recommendations only - it is the users responsibility to ensure the product is suitable for their specific application requirements.



PRESSURE TECH LTD

Unit 24, Graphite Way, Hadfield, Glossop, Derbyshire, UK, SK13 1QH

+44 (0)1457 899 307 | sales@pressure-tech.com | www.pressure-tech.com

DESIGNED, MANUFACTURED AND BUILT IN THE UK

© 2025 Pressure Tech Ltd. All Rights Reserved.

200325

PAGE:
1 OF 4

DRAWINGS AND INSTALLATION DIMENSIONS

Dimensions shown for 1/4" NPT option and standard configurations only – please contact the office for other options.

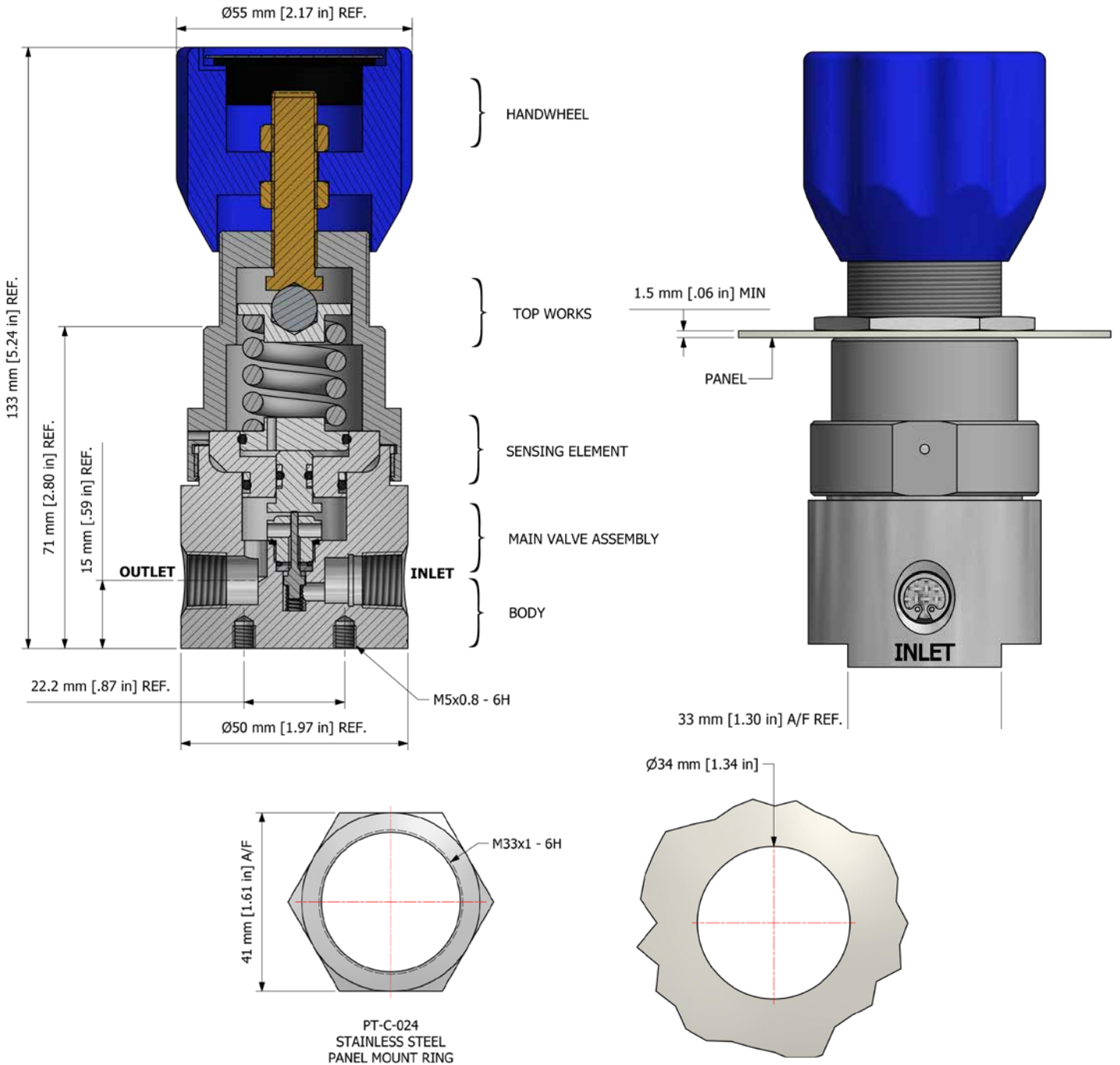

Note:
All gauge ports are 1/4" NPT as standard.

Product availability and specifications contained herein are subject to change without notice. Consult local distributor or factory for potential revisions and/or service related issues. Pressure Tech Ltd support with product selection recommendations only - it is the users responsibility to ensure the product is suitable for their specific application requirements.



FLOW CURVE

Please contact the office for further information.

PORTING CONFIGURATIONS

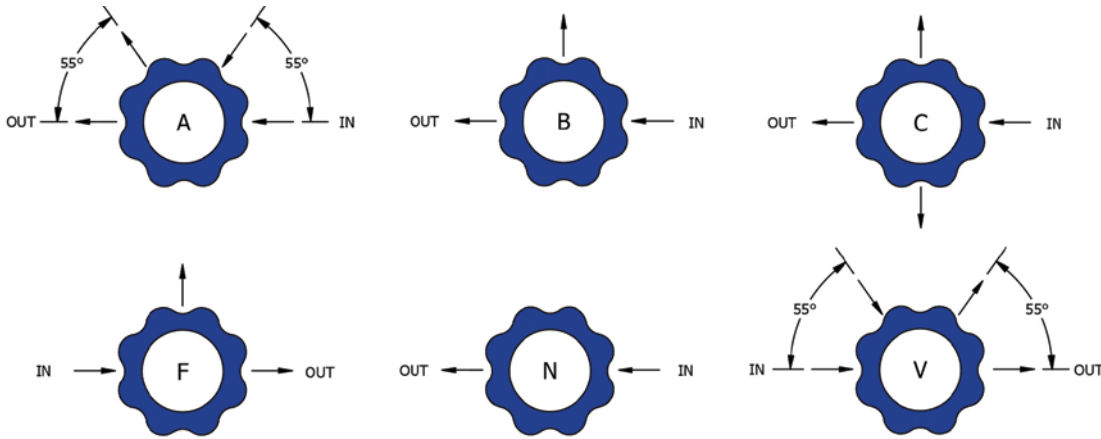

Note:

Additional porting configurations are available - please contact the office for further information.

Product availability and specifications contained herein are subject to change without notice. Consult local distributor or factory for potential revisions and/or service related issues. Pressure Tech Ltd support with product selection recommendations only - it is the users responsibility to ensure the product is suitable for their specific application requirements.



LF311 Datasheet

LOW-FLOW PRESSURE REGULATOR



Gas
 Liquid
 Diaphragm
 Piston
 Self-Venting
 Non-Venting
 Max Inlet: 414 bar (6,000 psi)
 Max Outlet: 180 bar (2,610 psi)
 Cv 0.06

ORDERING INFORMATION

To build a Pressure Tech part number, simply combine the characters identified below in sequence:

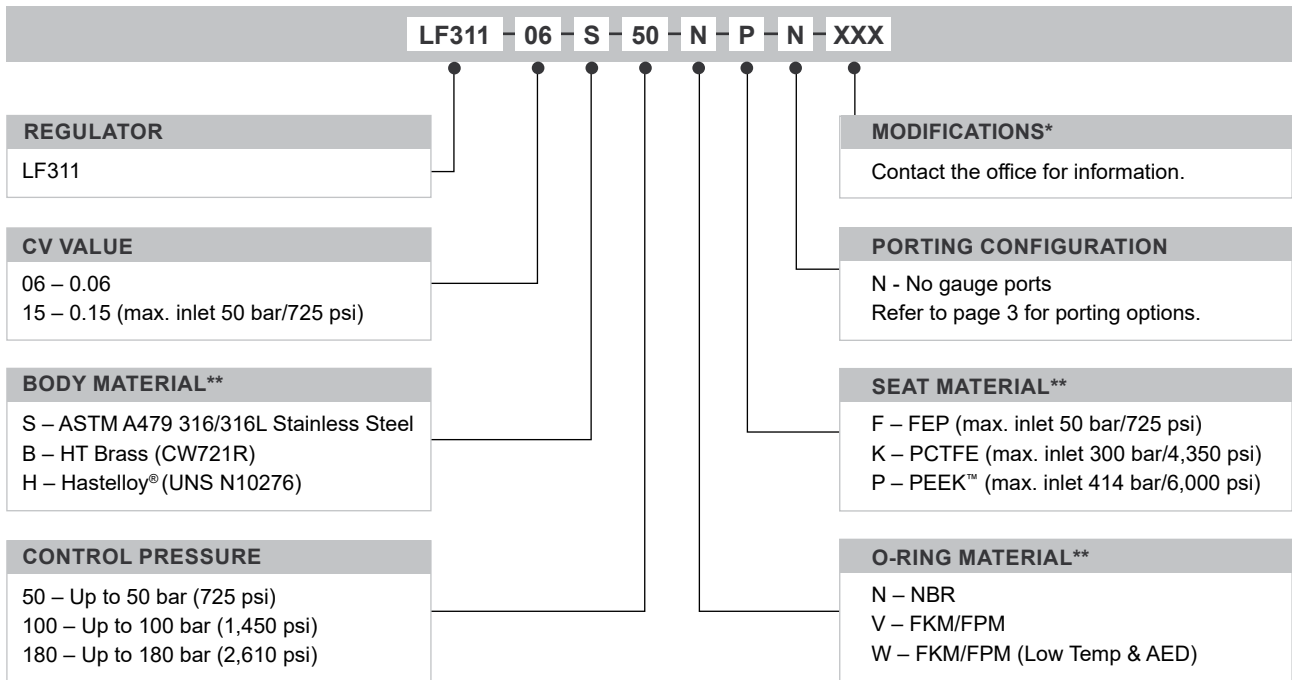

OPTIONAL EXTRAS		
	PART NUMBER	DESCRIPTION
Service Kit	SRK-LF311...	Various options available
Panel Mounting Ring	PT-C-024	-

Note: Ancillary equipment also available

TRADEMARKS: PEEK™ is a trademark of Victrex PLC
 Inconel® is a registered trademark of Inco Alloys International
 Hastelloy® is a registered trademark of Haynes International, Inc

* Where applicable
 ** Other materials may be available

Product availability and specifications contained herein are subject to change without notice. Consult local distributor or factory for potential revisions and/or service related issues.
 Pressure Tech Ltd support with product selection recommendations only - it is the users responsibility to ensure the product is suitable for their specific application requirements.



PRESSURE TECH LTD
 Unit 24, Graphite Way, Hadfield, Glossop, Derbyshire, UK, SK13 1QH
 +44 (0)1457 899 307 | sales@pressure-tech.com | www.pressure-tech.com
DESIGNED, MANUFACTURED AND BUILT IN THE UK
 © 2025 Pressure Tech Ltd. All Rights Reserved.

200325